



ERGOPLUS

240 - 400- 400R - 500 - 500R - 555



IT Manuale d'uso e manutenzione

EN Operating and maintenance manual

DE Bedienungsanleitung und Wartungshandbuch

FR Manuel d'utilisation et d'entretien

ES Manual de instrucciones y mantenimiento

TR Kullanım ve bakım kılavuzu



DICHIARAZIONE DI CONFORMITÀ

Trafimet Group Spa, azienda manifatturiera italiana regolarmente registrata, con sede in Via del Lavoro 8, 36020 Castegnero (VI), dichiara che i prodotti identificati e descritti nel presente manuale sono conformi a quanto previsto dalla Direttiva 2014/35 UE sulle basse tensioni e agli standard stabiliti dalla EN 60974-7 Attrezzatura per la saldatura ad arco - Parte 7.



DICHIARAZIONE DI CONFORMITÀ

Trafimet Group Spa, azienda manifatturiera italiana regolarmente registrata, con sede in Via del Lavoro 8, 36020 Castegnero (VI), dichiara che i prodotti identificati e descritti nel presente manuale sono conformi a quanto previsto dalle Normative del 2016 sulle apparecchiature elettriche (sicurezza) e dalle Normative del 2012 sull'uso di determinate sostanze pericolose nelle apparecchiature elettriche ed elettroniche.

IDENTIFICAZIONE DEL PROCESSO

Le torce di saldatura MIG/MAG manuali ERGOPLUS sono progettate per saldare materiali scarsamente o altamente legati.

AVVERTENZE



Prima di utilizzare le torce, è necessario leggere attentamente il manuale d'uso e manutenzione.



Condizioni ambientali
Funzionamento:
Da -10 °C a +40 °C (da +14 °F a +104 °F)

Trasporto e stoccaggio:
Da -25 °C a +55 °C (da -13 °F a +131 °F)

Umidità relativa:
Fino al 90% a 20 °C (68 °F)

Spegnere la fonte di alimentazione prima di eseguire la manutenzione della torcia. La sostituzione delle parti di ricambio o attività di manutenzione di altro tipo devono essere effettuate dopo il raffreddamento della torcia.



NO VOLTAGE



Smaltire questo prodotto in modo responsabile dopo l'uso. Le torce e le parti usate devono essere adeguatamente riciclate in conformità ai requisiti/alle normative locali.

PRECAUZIONI DI SICUREZZA



Indossare guanti e altri indumenti da lavoro adeguati in conformità alle normative locali.



L'arco è pericoloso per gli occhi. Indossare un casco protettivo. Le persone nelle vicinanze devono indossare una protezione per gli occhi.



Non eseguire saldature in siti infiammabili o esplosivi.



I fumi sono pericolosi per la salute. Usare sistemi per l'aspirazione dei fumi oppure eseguire saldature esclusivamente in ambienti ventilati.



Rivolgere la torcia lontano da sa stessi e dagli altri.



Non eseguire saldature su superfici verniciate.



Proteggere gli utensili elettrici dalla pioggia. Non utilizzare la torcia di saldatura su superfici o pavimenti bagnati oppure in ambienti con un'umidità elevata.



I cavi della torcia non devono essere schiacciati da oggetti pesanti.



Non modificare la torca né apportare modifiche strutturali ad essa.

COLLEGAMENTO



NO VOLTAGE



Prima di collegare la torcia, spegnere la fonte di alimentazione, staccare la spina e chiudere la fornitura di gas.



Prima di collegare la torcia alla fonte di alimentazione, verificare che i collegamenti elettrici siano corretti e in conformità agli schemi elettrici allegati, laddove applicabile.



Controlla la circolazione/il flusso del refrigeramento della torcia.

UTILIZZO



Accertarsi che la guaina in filo metallico e la punta di contatto corrispondano al diametro del filo di riempimento.



Non piegare i cavi e i tubi flessibili per evitare danni che potrebbero impedire la corretta circolazione del gas e del refrigerante.



Non usare la torcia per scopi diversi dalla saldatura.

MANUTENZIONE



NO VOLTAGE



Spegnere la fonte di alimentazione prima di eseguire la manutenzione della torcia. La sostituzione delle parti di ricambio o attività di manutenzione di altro tipo devono essere effettuate dopo il raffreddamento della torcia.



Se la punta di contatto è usurata o danneggiata, sostituirla.



Pulire periodicamente l'ugello del gas e il diffusore di gas. Utilizzare uno spray antiadesivo.



Sostituire la guaina in filo metallico se ci sono problemi con il trainafilo.



Controllare periodicamente le condizioni del cavo e del manico. Le riparazioni possono essere eseguite solo da personale qualificato.



Usare sempre parti di ricambio e materiali di consumo originali Trafimet.

FUNZIONAMENTO



Informazioni importanti su come utilizzare la torcia di saldatura MIG in modo sicuro. Classificazione dei comandi elettrici della torcia: 32 V CC 0,05 A.

Alimentazione dell'unità di raffreddamento per torce raffreddate ad acqua: almeno 800 W.



Prima di usare la torcia, accertarsi che tutti i cavi siano in buone condizioni e che i connettori siano fissati correttamente.

Come collegare la torcia

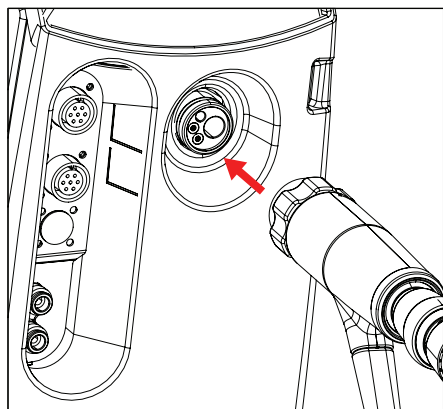

Collegare la torcia alle attrezzature di saldatura.
Fissare il connettore ruotando il collare in senso orario.

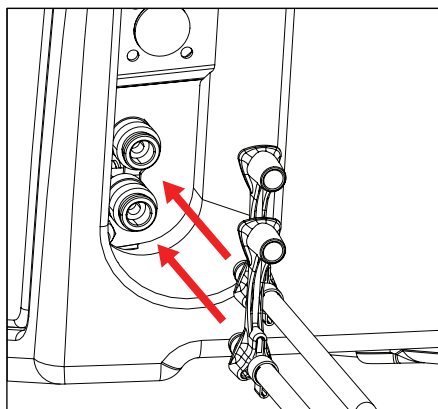

Collegare i tubi flessibili di ingresso e uscita del refrigerante all'attrezzatura di saldatura. Si noti che i connettori seguono una codifica a colori.



Assicurarsi di collegare i tubi flessibili del refrigerante ai connettori per tubi flessibili corretti.
Se i collegamenti si incrociano, la torcia di saldatura può surriscaldarsi.

FUNZIONAMENTO

Come installare e sostituire la guaina in filo metallico

Le torce di saldatura MIG ERGOPLUS vengono fornite con la guaina in filo metallico preinstallata. Consultare questa sezione quando è necessario sostituire la guaina guidafile. La guaina guidafile è un materiale di consumo che deve essere cambiato in caso di usura o quando si cambia il materiale del filo.



Se si cambia il filo di riempimento con un filo di diametro o materiale diverso, è necessario cambiare anche i rulli di alimentazione nel sistema trainafile. Prima di sostituire la guaina guidafile, è necessario rimuovere il filo di riempimento.

- 1 Raddrizzare il cavo della torcia di saldatura e rimuovere il dado della guaina.

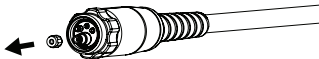

- 2 Rimuovere l'ugello del gas e la punta di contatto. Se la guaina in filo metallico non passa attraverso il supporto della punta, rimuovere anche il supporto della punta.

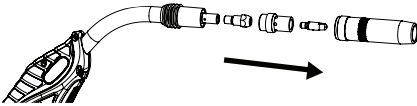

- 3 Tagliare la guaina in filo metallico lasciando 1-2 mm di guaina in eccesso.

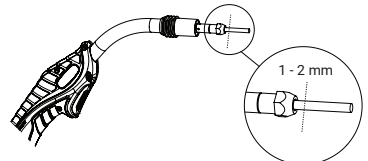
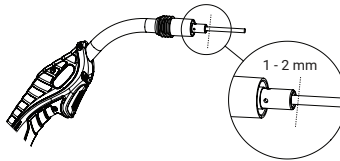

- 4 Rimuovere i bordi ruvidi che potrebbero danneggiare il filo di riempimento.

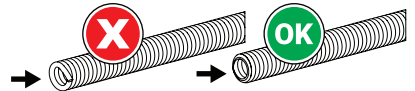

- 5 Riavvitare il dado della guaina in posizione e serrarlo con uno strumento.

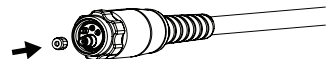

Come installare e rimuovere l'impugnatura

- 1 Mantenendo la parte inferiore dell'impugnatura rivolta in avanti, inserire le scanalature interne dell'impugnatura sopra le viti della torcia.

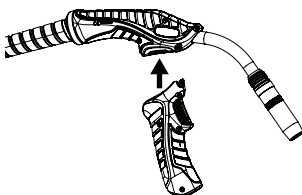

- 2 Tirare l'impugnatura all'indietro per bloccarla in posizione.

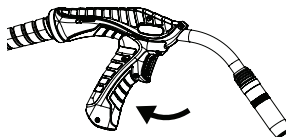

- 3 Per rimuovere l'impugnatura, premere il pulsante di blocco situato nella parte posteriore dell'impugnatura.

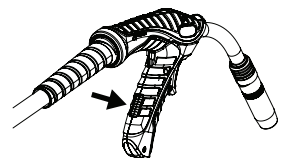



DECLARATION OF CONFORMITY

Trafimet Group Spa, a duly registered Italian Manufacturing Company, located in Via del Lavoro, 8 36020 Castegnero (VI), hereby declares that products identified and described in this manual are in conformity with the provisions of Low Voltage Directive 2014/35 EU and in compliance with the standards set by EN 60974-7 Arc Welding Equipment - Part 7.



DECLARATION OF CONFORMITY

Trafimet Group Spa, a duly registered Italian Manufacturing Company, located in Via del Lavoro, 8 36020 Castegnero (VI), hereby declares that the products identified and described in this manual comply with the provisions of the Electrical Equipment (Safety) Regulations 2016 and the Restriction of the Use of Certain Hazardous Substances in Electrical and Electronic Equipment Regulations 2012.

PROCESS IDENTIFICATION

ERGOPLUS manual MIG/MAG welding torches are designed for welding low and high-alloy materials.

WARNINGS



Please read carefully the operating and maintenance manual before use.



Turn off power source before performing torch maintenance. Replacement of any spare parts or other maintenance must be performed after the torch has cooled down.



NO VOLTAGE



Ambient conditions
Operation:
-10°C to +40°C (+14°F to +104°F)

Transport and storage:
-25°C to +55°C (-13°F to +131°F)

Relative humidity:
Up to 90 % at 20°C (68°F)

Dispose of this product responsibly after use. Torches and used parts should be properly recycled according to the local requirements/regulations.



SAFETY PRECAUTIONS



Wear gloves and other suitable workwear in accordance with local regulations.



Arc is dangerous to the eyes. Wear a protective helmet. Nearby people should wear eye protection.



Do not weld in flammable or explosive sites.



Fumes are hazardous to health. Use fume extraction systems or weld in ventilated spaces only.



Point the torch away from yourself and others.



Do not weld on painted surfaces.



Protect power tools from rain. Do not use the welding torch on wet surfaces/floors or in spaces with high humidity.



Torch cables must not be squashed by heavy objects.



Do not modify or make structural changes to the torch.

CONNECTION



NO VOLTAGE



Before connecting the torch, switch off the power source, disconnect the power plug and shut off the gas supply.



Before connecting the torch to the power source, check the correct electrical connections according to the enclosed wiring diagrams, where applicable.



Check the torch coolant circulation/flow.

USE



Make sure that the wire liner and contact tip match the diameter of the filler wire.



Do not bend cables and hoses in order to avoid damages that may prevent proper gas and coolant circulation.



Do not use the torch for purposes other than welding.

MAINTENANCE



NO VOLTAGE



Turn off the power source before performing torch maintenance. Replacement of any spare parts or other maintenance must be performed after the torch has cooled down.



Replace the contact tip if it is worn or damaged.



Clean the gas nozzle and gas diffuser periodically. Use anti-adhesive spray.



Replace the wire liner if there are problems with the wire feed.



Check the condition of the cable and handle periodically. Repairs may be carried out by qualified personnel only.



Always use the original Trafimet spare parts and consumables.

OPERATION



Important information about safe operation of the MIG welding torch. Rating of electrical controls included in the torch: 32VDC 0.05A.

Cooling unit power for water-cooled torches: Minimum 800W.



Before using the torch, ensure that all the cables are in serviceable condition and that the connectors are correctly fastened.

How to connect the torch

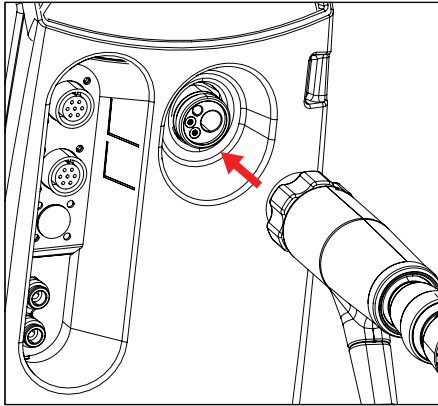

Connect the torch to your welding equipment.
Secure the connector in place by turning the collar clockwise.

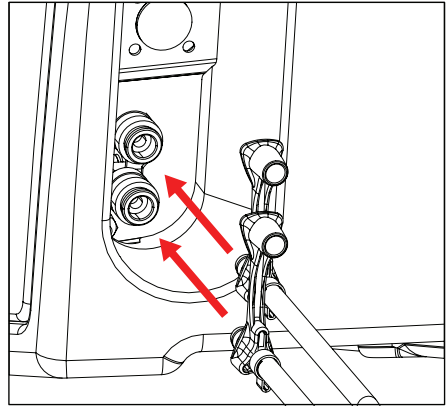

Connect the coolant inlet and outlet hose to your welding equipment.
Note that the connectors are color-coded.



Make sure to connect the coolant hoses to the correct hose connectors. If the connections cross, the welding torch may overheat.

OPERATION

How to install and replace wire liner

ERGOPLUS MIG welding torches are delivered with the wire liner preinstalled. Refer to this section when the wire liner needs to be replaced.

The wire liner is a consumable part, which needs to be changed if worn and when the filler wire material changes.



If you change the filler wire to a different diameter or material, change also the feed rolls in the wire feed system accordingly.

The filler wire must be removed before the wire liner replacement.

- ① Straighten the welding torch cable and remove the liner nut.

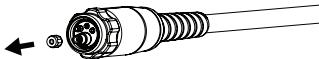

- ② Remove the gas nozzle and the contact tip. If the wire liner does not pass through the tip holder, remove the tip holder as well.

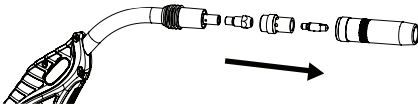

- ③ Cut the wire liner leaving 1-2 mm of excess liner.

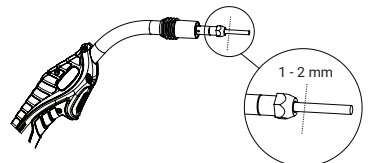
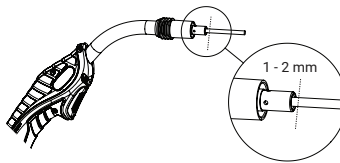

- ④ Remove any rough edges that could potentially damage the filler wire.

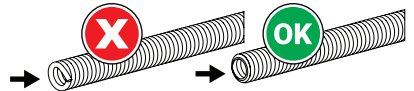

- ⑤ Screw the liner nut back in place and tighten it with a tool.

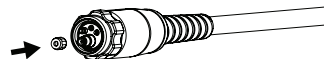

How to install and remove grip handle

- ① Keeping the bottom of the grip handle pointing forward, fit the inside grooves of the grip handle over the screws on the torch.

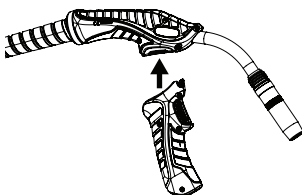

- ② Pull the handle backward to lock it in position.

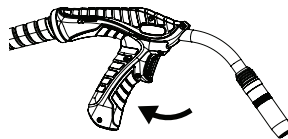

- ③ To remove the grip handle, press the lock button in the grip handle rear.

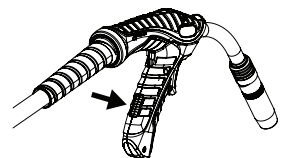



KONFORMITÄTSERKLÄRUNG

Trafimet Group Spa, ein ordnungsgemäß eingetragenes italienisches Produktionsunternehmen mit Sitz in der Via del Lavoro, 8 36020 Castegnero (VI), erklärt hiermit, dass die in diesem Handbuch bezeichneten und beschriebenen Produkte den Bestimmungen der Niederspannungsrichtlinie 2014/35 EU und den von der EN 60974-7 Lichtbogenschweißeinrichtungen – Teil 7 festgelegten Normen entsprechen.



KONFORMITÄTSERKLÄRUNG

Trafimet Group Spa, ein ordnungsgemäß eingetragenes italienisches Produktionsunternehmen mit Sitz in der Via del Lavoro, 8 36020 Castegnero (VI), erklärt hiermit, dass die in diesem Handbuch bezeichneten und beschriebenen Produkte den Bestimmungen im Hinblick auf die Sicherheit von Elektrogeräten aus dem Jahr 2016 und der Beschränkung der Verwendung bestimmter Gefahrenstoffe in Elektro- und Elektronikgeräten aus dem Jahr 2012 entsprechen.

PROZESSBESTIMMUNG

Die manuellen MIG/MAG-Brenner ERGOPLUS sind zum Schweißen von niedrig- und hochlegierten Materialien konzipiert.

WARNHINWEISE



Bitte lesen Sie die Bedienungs- und Wartungsanleitung vor dem Gebrauch sorgfältig durch.



Schalten Sie die Stromquelle vor der Durchführung von Wartungsarbeiten am Brenner aus. Der Austausch von Ersatzteilen oder andere Wartungsarbeiten dürfen erst durchgeführt werden, nachdem sich der Brenner abgekühlt hat.



NO VOLTAGE



Umgebungsbedingungen
Betrieb:
-10 °C bis +40 °C

Entsorgen Sie das Produkt nach Gebrauch verantwortungsbewusst. Brenner und gebrauchte Teile sind immer ordnungsgemäß (gemäß den geltenden lokalen Anforderungen/Vorschriften) zu recyceln.



Transport und Lagerung:
-25 °C bis +55 °C

Relative Luftfeuchtigkeit:
Bis zu 90 % bei 20 °C

SICHERHEITSHINWEISE



Tragen Sie Handschuhe und weitere geeignete Arbeitskleidung gemäß den örtlichen Vorschriften.



Der Lichtbogen ist gefährlich für die Augen. Tragen Sie einen Helm. In der Nähe befindliche Personen sollten einen Augenschutz tragen.



Nicht an entflammaren oder explosiven Orten



Dämpfe sind gesundheitsschädlich. Rauchabsauganlagen verwenden oder nur in gut belüfteten Räumen schweißen.



Brenner immer von sich selbst und anderen entfernt halten.



Nicht auf lackierten Oberflächen schweißen.



Elektrowerkzeuge vor Regen schützen. Den Schweißbrenner nicht auf nassen Oberflächen/Böden oder in Räumen mit hoher Luftfeuchtigkeit verwenden.



Brennerkabel dürfen nicht von schweren Gegenständen gequetscht werden.



Keine baulichen Veränderungen am Brenner vornehmen.

ANSCHLUSS



NO VOLTAGE



Schalten Sie die Stromquelle vor dem Anschließen des Brenners aus, ziehen Sie den Netzstecker und schalten Sie die Gaszufuhr ab.



Vor dem Anschließen des Brenners an die Stromquelle prüfen Sie ggf. die korrekten elektrischen Anschlüsse gemäß den beiliegenden Schaltplänen.



Überprüfen Sie Zirkulation/Durchfluss des Brennerkühlmittels.

VERWENDUNG



Achten Sie darauf, dass der Drahtleiter und die Stromdüse dem Durchmesser des Fülldrahts entsprechen.



Knicken Sie die Kabel und Schläuche nicht ab, um Schäden zu vermeiden, die eine ordnungsgemäße Gas- und Kühlmittelzirkulation verhindern können.



Verwenden Sie den Brenner nicht für andere Zwecke als zum Schweißen.

WARTUNG



NO VOLTAGE



Schalten Sie die Stromquelle vor der Durchführung von Wartungsarbeiten am Brenner aus. Der Austausch von Ersatzteilen oder andere Wartungsarbeiten dürfen erst durchgeführt werden, nachdem sich der Brenner abgekühlt hat.



Ersetzen Sie die Stromdüse, wenn sie abgenutzt oder beschädigt ist.



Ersetzen Sie den Drahtleiter bei Problemen mit dem Drahtvorschub.



Reinigen Sie die Gasdüse und den Gasverteiler regelmäßig. Verwenden Sie Antihafspray.



Überprüfen Sie regelmäßig den Zustand des Kabels und der Zuleitung. Reparaturen dürfen nur von qualifiziertem Personal durchgeführt werden.



Verwenden Sie immer Original-Ersatzteile und -Verschleißteile von Trafimet.

BETRIEB



Wichtige Informationen zum sicheren Betrieb des MIG-Schweißbrenners. Nennwerte der im Brenner enthaltenen elektrischen Steuerungen: 32 V DC, 0,05 A

Leistung der Kühleinheit für wassergekühlte Brenner: Min. 800 W



Vergewissern Sie sich vor der Verwendung des Brenners, dass alle Kabel in betriebsbereitem Zustand und die Anschlüsse ordnungsgemäß befestigt sind.

So schließen Sie den Brenner an

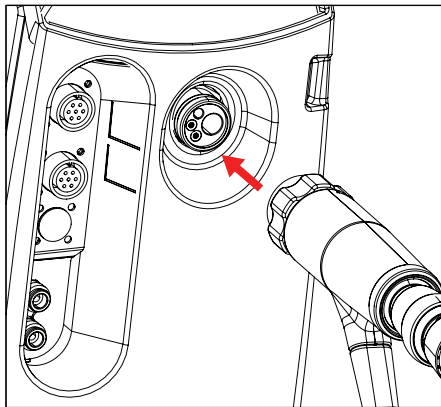

Schließen Sie den Brenner an Ihr Schweißgerät an.
Sichern Sie den Anschluss durch Drehen des Ringes im Uhrzeigersinn.

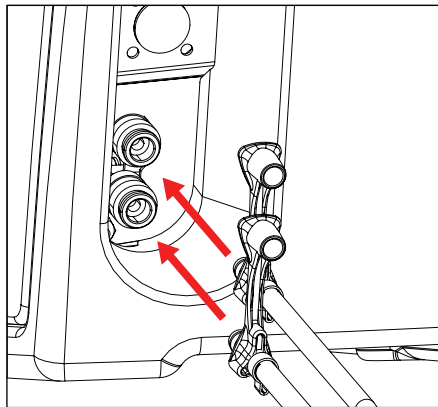

Verbinden Sie den Ein- und Ausgangsschlauch für das Kühlmittel mit Ihrer Schweißmaschine. Beachten Sie, dass die Anschlüsse farbcodiert sind.



Achten Sie darauf, dass Sie die Kühlmittelschläuche mit den richtigen Schlauchanschlüssen verbinden. Bei vertauschten Anschlüssen kann der Schweißbrenner überhitzen.

BETRIEB

So montieren und ersetzen Sie den Drahtleiter

ERGOPLUS MIG-Schweißbrenner werden mit vormontiertem Drahtleiter geliefert. Lesen Sie diesen Abschnitt, wenn der Drahtleiter ausgetauscht werden muss. Der Drahtleiter ist Verbrauchsmaterial und muss ersetzt werden, wenn er verschlissen ist oder der Zusatzwerkstoff geändert wird.



Wenn Sie den Fülldraht auf einen anderen Durchmesser oder ein anderes Material umstellen, ändern Sie auch die Vorschubrollen im Drahtvorschubsystem entsprechend. Der Fülldraht muss vor dem Ersatz des Drahtleiters entfernt werden.

- 1 Richten Sie das Schweißbrennerkabel aus und entfernen Sie die Mutter vom Leiter.

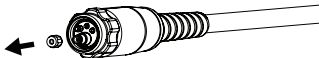

- 2 Entfernen Sie Gasdüse und Stromdüse. Wenn der Drahtleiter nicht durch den Düsenhalter verläuft, entfernen Sie auch den Düsenhalter.

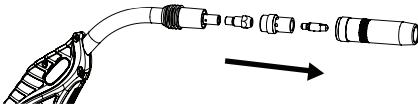

- 3 Schneiden Sie den Drahtleiter so ab, dass noch 1–2 mm des Leiters hervorstehen.

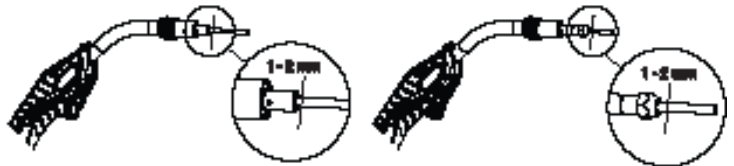

- 4 Entfernen Sie sämtliche rauen Kanten, die den Fülldraht beschädigen könnten.

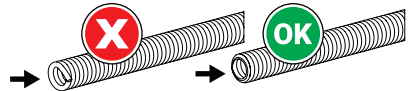

- 5 Schrauben Sie die Mutter wieder ein und ziehen Sie sie mit einem Werkzeug fest.

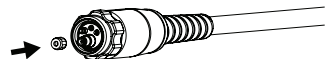

So montieren und entfernen Sie den Griff

- 1 Halten Sie die Unterseite des Griffs nach vorne gerichtet und setzen Sie die Innenrillen des Griffs über die Schrauben des Brenners.

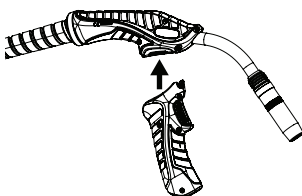

- 2 Ziehen Sie den Griff zurück, um ihn in Position zu arretieren.

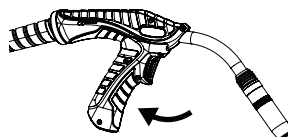

- 3 Drücken Sie den Verriegelungsknopf an der Rückseite des Griffs, um den Griff zu entfernen.

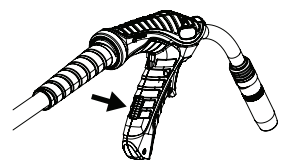

**DÉCLARATION DE CONFORMITÉ**

Trafimet Group Spa, entreprise de fabrication italienne dûment immatriculée, sise Via del Lavoro, 8 36020 Castegnero (VI), déclare par la présente que les produits identifiés et décrits dans ce manuel sont conformes aux dispositions de la directive Basse tension 2014/35/UE et conformes aux normes établies par EN 60974-7 Équipement de soudage à l'arc - Partie 7.

**DÉCLARATION DE CONFORMITÉ**

Trafimet Group Spa, entreprise de fabrication italienne dûment immatriculée, sise Via del Lavoro, 8 36020 Castegnero (VI), déclare par la présente que les produits identifiés et décrits dans ce manuel sont conformes aux dispositions des règlements 2016 relatifs à la sécurité des équipements électriques ainsi qu'aux dispositions des règlements 2012 de limitation de l'utilisation de certaines substances dangereuses dans les équipements électriques et électroniques.

IDENTIFICATION DES PROCESSUS

Les torches de soudage MIG/MAG manuelles ERGOPLUS sont conçues pour le soudage des matériaux faiblement et fortement alliés.

AVERTISSEMENTS

Veuillez lire attentivement le manuel d'utilisation et d'entretien avant toute utilisation.



Conditions ambiantes
Utilisation :
-10 °C à +40 °C (+14 °F à +104 °F)

Transport et stockage :
-25 °C à +55 °C (-13 °F à +131 °F)

Humidité relative :
Jusqu'à 90 % à 20 °C (68 °F)

PRÉCAUTIONS DE SÉCURITÉ

Portez des gants et des vêtements de travail appropriés conformément aux réglementations locales.



L'arc est dangereux pour les yeux. Portez un casque de protection. Les personnes situées à proximité doivent porter des lunettes de protection.



Ne soudez pas dans des environnements inflammables ou explosifs.



Les fumées sont dangereuses pour la santé. Utilisez des systèmes d'extraction de fumées ou soudez uniquement dans des espaces ventilés.



Dirigez la torche à l'écart des autres personnes et de vous-même.



Ne soudez pas sur des surfaces peintes.



Protégez les outils électriques de la pluie. N'utilisez pas la torche de soudage sur des surfaces/sols mouillés ou dans des espaces très humides.



Les câbles des torches ne doivent pas être écrasés par des objets lourds.



Ne modifiez pas et n'apportez pas de changements structurels à la torche.

CONNEXION



NO VOLTAGE



Avant de connecter la torche, éteignez le poste à souder, débranchez la fiche électrique et coupez l'alimentation en gaz.



Avant de connecter la torche au poste à souder, assurez-vous que les branchements électriques sont corrects en fonction des schémas de câblage fournis, le cas échéant.



Vérifiez la circulation/ le débit du liquide de refroidissement de la torche.

UTILISATION



Assurez-vous que la gaine et le tube contact correspondent au diamètre du fil d'apport.



Ne pliez pas les câbles et les tuyaux afin d'éviter des dommages qui pourraient empêcher une circulation correcte du gaz et du liquide de refroidissement.



N'utilisez pas la torche à d'autres fins que le soudage.

ENTRETIEN



NO VOLTAGE



Éteignez le poste à souder avant d'effectuer l'entretien de la torche. Le remplacement des pièces de rechange et les autres opérations d'entretien doivent être effectués une fois que la torche a refroidi.



Remplacez le tube contact s'il est usé ou endommagé.



Nettoyez régulièrement la buse de gaz et le diffuseur de gaz. Utilisez un spray anti-adhésif.



Remplacez la gaine en cas de problèmes de dévidage.



Vérifiez régulièrement l'état du câble et de la poignée. Les réparations ne peuvent être effectuées que par du personnel qualifié.



Utilisez toujours les pièces détachées et les consommables Trafimet d'origine.

UTILISATION



Informations importantes concernant la sécurité de fonctionnement de la torche de soudage MIG. Calibre des commandes électriques incluses dans la torche : 32 V CC 0,05 A.

Puissance de l'unité de refroidissement pour les torches à refroidissement par eau : 800 W minimum.



Avant d'utiliser la torche, assurez-vous que tous les câbles sont en bon état de fonctionnement et que les connecteurs sont correctement fixés.

Comment connecter la torche

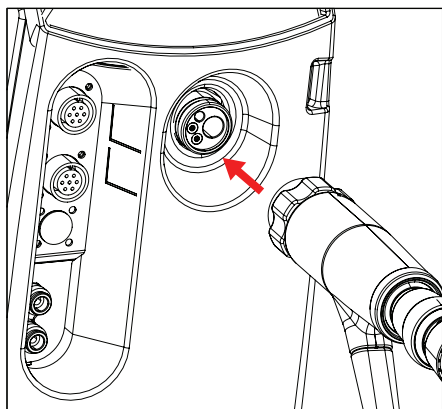

Connectez la torche à votre équipement de soudage. Fixer le connecteur en place en tournant la bague dans le sens des aiguilles d'une montre.

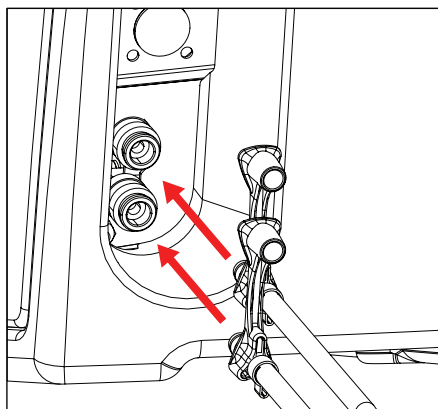

Raccordez le tuyau d'arrivée et sortie d'eau de refroidissement à l'équipement de soudage. Noter que les connecteurs sont codés par couleur.



Veiller à raccorder les tuyaux de liquide de refroidissement aux bons connecteurs. En cas d'inversion des connexions, la torche de soudage peut surchauffer.

UTILISATION

Comment installer et remplacer la gaine

Les torches de soudage MIG ERGOPLUS sont livrées avec une gaine préinstallée. Se reporter à cette section pour remplacer la gaine. La gaine est un consommable qui doit être changé en cas d'usure ou de changement de matériau de fil d'apport.



Si vous devez changer le fil d'apport (avec un diamètre ou un matériau différent), changez également les galets du dévidoir en conséquence. Le fil d'apport doit être retiré avant de remplacer la gaine.

- 1 Redressez le câble de la torche de soudage et retirez l'écrou de la gaine.

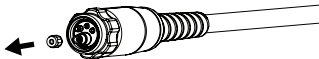

- 2 Retirez la buse de gaz et le tube de contact. Si la gaine ne passe pas dans le support de tube contact, retirez également le support de tube contact.

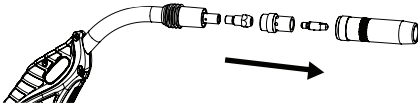

- 3 Coupez la gaine en laissant 1 à 2 mm de gaine en excès.

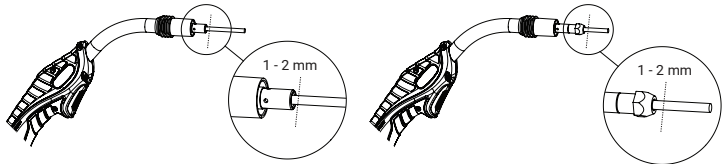

- 4 Retirez les aspérités qui pourraient endommager le fil d'apport.

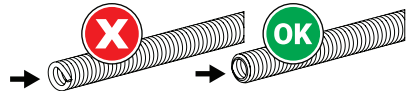

- 5 Revissez l'écrou de la gaine en position et serrez-le avec un outil.

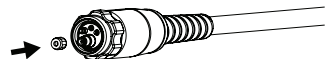

Comment installer et retirer la poignée

- 1 Tenez la base de la poignée orientée vers l'avant et placez les rainures internes de la poignée sur les vis de la torche.

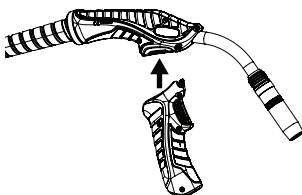

- 2 Tirer la poignée en arrière pour la verrouiller en position.

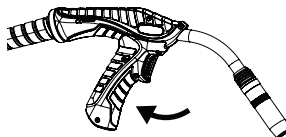

- 3 Pour retirer la poignée, appuyez sur le bouton de verrouillage situé à l'arrière de la poignée.

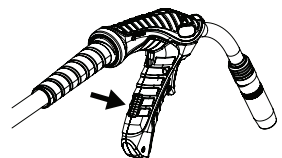



DECLARACIÓN DE CONFORMIDAD

Trafimet Group Spa, empresa de fabricación italiana debidamente registrada, con sede en Via del Lavoro, 8 36020 Castegnero (VI), por la presente declara que los productos que se identifican y describen en el presente manual están en conformidad con las disposiciones de la Directiva de Baja Tensión 2014/35 UE y en cumplimiento de las normas estipuladas por la EN 60974-7 Equipos de soldadura por arco - Apartado 7.



DECLARACIÓN DE CONFORMIDAD

Trafimet Group Spa, empresa de fabricación italiana debidamente registrada, con sede en Via del Lavoro, 8 36020 Castegnero (VI), por la presente declara que los productos que se identifican y cumplen las disposiciones del Reglamento sobre equipos eléctricos (seguridad) de 2016 y el Reglamento sobre restricciones a la utilización de determinadas sustancias peligrosas en equipos eléctricos y electrónicos de 2012.

IDENTIFICACIÓN DEL PROCESO

Las antorchas de soldadura manuales MIG/MAG de ERGOPLUS se han diseñado para soldar materiales de aleación baja y alta.

ADVERTENCIAS



Antes de su uso, lea detenidamente el manual de uso y mantenimiento.



Antes de efectuar el mantenimiento de la antorcha, apague la fuente de potencia. El cambio de repuestos o cualquier tipo de mantenimiento deben efectuarse una vez que se haya enfriado la antorcha.



NO VOLTAGE



Condiciones ambientales
Funcionamiento:
De -10 °C a +40 °C (de +14 °F a +104 °F)

Después de utilizar este producto, deséchelo de forma responsable. Las antorchas y las piezas usadas se deben reciclar de forma adecuada según los requisitos/ reglamentos locales.



Transporte y almacenamiento:
De -25 °C a +55 °C (de -13 °F a +131 °F)

Humedad relativa:
Hasta 90 % a 20 °C (68 °F)

PRECAUCIONES DE SEGURIDAD



Utilice guantes y ropa de trabajo adecuada según la normativa local.



El arco es peligroso para los ojos. Utilice una máscara de protección. Las personas que se encuentren cerca deben llevar protección ocular.



No realice la soldadura en lugares con riesgo de inflamación o explosión.



Los humos representan un peligro para la salud. Use sistemas de extracción de humos o efectúe la soldadura únicamente en espacios ventilados.



No dirija la antorcha hacia usted ni hacia otras personas.



No realice la soldadura sobre superficies pintadas.



Proteja de la lluvia las herramientas eléctricas. No utilice la antorcha de soldadura sobre superficies o suelos mojados ni en espacios donde haya mucha humedad.



Evite que objetos pesados aplasten los cables de la antorcha.



No modifique ni haga cambios estructurales en la antorcha.

CONEXIÓN



NO VOLTAGE



Antes de conectar la antorcha, apague la fuente de potencia, desconecte el enchufe y cierre el suministro de gas.



Antes de conectar la antorcha a la fuente de potencia, compruebe que las conexiones eléctricas son correctas según los diagramas de cableado adjuntos, si procede.



Compruebe la circulación y el flujo del refrigerante de la antorcha.

USO



Compruebe que el conductor de alambre y la punta de contacto coinciden con el diámetro del alambre de relleno.



No doble los cables ni las mangueras a fin de evitar daños que impidan la correcta circulación del gas y del refrigerante.



No use la antorcha para otros fines que no sean la soldadura.

MANTENIMIENTO



NO VOLTAGE



Antes de efectuar el mantenimiento de la antorcha, apague la fuente de potencia. El cambio de repuestos o cualquier tipo de mantenimiento deben efectuarse una vez que se haya enfriado la antorcha.



Si la punta de contacto está desgastada o dañada, reemplácela.



Limpie periódicamente la boquilla y el difusor de gas. Use un spray antiadherente.



Si hay problemas con la alimentación de alambre, reemplace el conductor de alambre.



Verifique periódicamente el estado del cable y del mango. Solo el personal cualificado puede llevar a cabo las reparaciones.



Use siempre los repuestos y los consumibles originales de Trafimet.

FUNCIONAMIENTO



Información importante sobre el funcionamiento seguro de la antorcha de soldadura MIG.
Clasificación de los controles eléctricos que incluye la antorcha: 32 VCC 0,05 A.

Potencia de unidad de refrigeración para antorchas refrigeradas por líquido: Mínimo 800 W.



Antes de utilizar la antorcha, compruebe que las condiciones de uso de todos los cables sean adecuadas y que los conectores están correctamente fijados.

Conexión de la antorcha

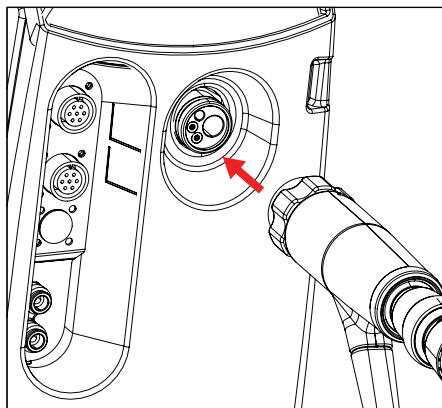

Conecte la antorcha al equipo de soldadura. Fije el conector en su lugar girando el collarín hacia la derecha.

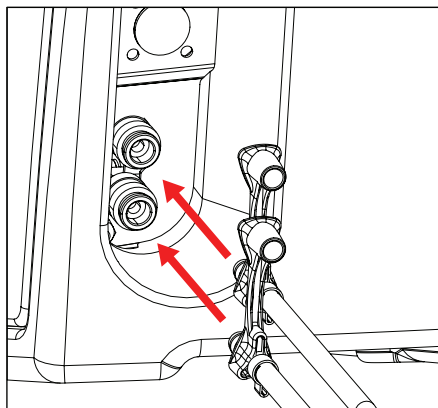

Conecte la manguera de entrada y salida de refrigerante al equipo de soldadura. Tenga en cuenta que los conectores están codificados por colores.



Asegúrese de conectar las mangueras del refrigerante a los conectores de manguera correctos. Si las conexiones se cruzan, la antorcha de soldadura puede sobrecalentarse.

FUNCIONAMIENTO

Instalación y reemplazo del conductor de alambre

Las antorchas de soldadura ERGOPLUS MIG tienen preinstalado el conductor de alambre cuando se entregan. Consulte esta sección cuando sea necesario reemplazar el conductor de alambre. El conductor flexible de alambre es una pieza consumible, que hay que cambiar si se desgasta y cuando el alambre de relleno cambia.



Si cambia el diámetro o el material del alambre de relleno, cambie también los rodillos de alimentación en el sistema de alimentación del alambre. El alambre de relleno debe retirarse antes de reemplazar el conductor de alambre.

- 1 Enderece el cable de la antorcha de soldadura y retire la tuerca del conductor.

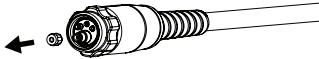

- 2 Retire la boquilla de gas y la punta de contacto. Retire también el soporte para puntas si el conductor de alambre no pasa por dicho soporte.

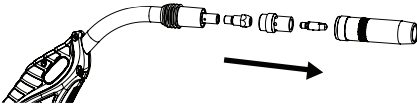

- 3 Corte el conductor de alambre y deje 1 o 2 mm de exceso de conductor.

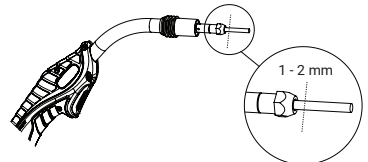
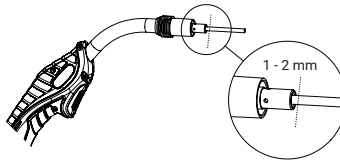

- 4 Retire los bordes ásperos que puedan dañar el alambre de relleno.

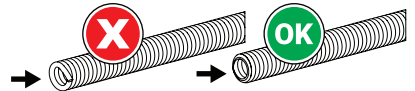

- 5 Enrosque la tuerca del conductor en su sitio y use una herramienta para apretarla.

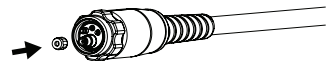

Instalación y extracción del mango

- 1 Manteniendo la parte inferior del mango apuntando hacia adelante, coloque las hendiduras internas del mango sobre los tornillos de la antorcha.

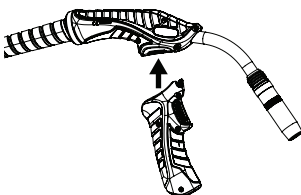

- 2 Tire del mango hacia atrás para bloquearlo en su posición.

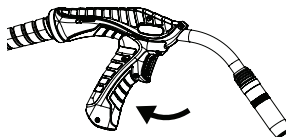

- 3 Para quitar el mango, presione el botón de bloqueo en la parte posterior del mango.

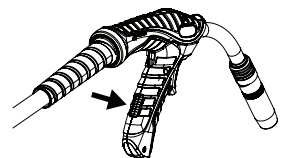

TR KULLANIM VE BAKIM KILAVUZU



UYGUNLUK BEYANI

Via del Lavoro, 8 36020 Castegnero (VI) adresinde yerleşik ve ilgili yasal mevzuat uyarınca kayıt altına alınan bir İtalyan İmalat Şirketi olan Trafimet Group Spa, işbu belgeyle, bu kılavuzda tanımlanan ve açıklanan ürünlerin, 2014/35 AB Aİçak Gerilim Yönetmeliği hükümlerine ve EN 60974-7 Ark Kaynak Ekipmanı - Bölüm 7'de belirlenmiş standartlara uygun olduğunu beyan eder.



UYGUNLUK BEYANI

Via del Lavoro, 8 36020 Castegnero (VI) adresinde yerleşik ve ilgili yasal mevzuat uyarınca kayıt altına alınan bir İtalyan İmalat Şirketi olan Trafimet Group Spa, işbu belgeyle, bu kılavuzda tanımlanan ve açıklanan ürünlerin Elektrikli Ekipman (Güvenlik) Yönetmeliği 2016 ve Elektrikli ve Elektronik Ekipman Yönetmeliği 2012'deki Bazı Tehlikeli Maddelerin Kullanımının Kısıtlanması hükümlerine uygun olduğunu beyan eder.

SÜREÇ TANIMI

ERGOPLUS manuel MIG/MAG kaynak torçları, düşük ve yüksek alaşımli malzemelerin kaynağı için tasarlanmıştır.

UYARILAR



Kullanmadan önce lütfen kullanım ve bakım kılavuzunu dikkatli şekilde okuyun.



Torç bakımını gerçekleştirmeden önce güç kaynağını kapatın. Herhangi bir yedek parça değişimi veya diğer bakım işlemleri torç soğuduktan sonra gerçekleştirilmelidir.



NO VOLTAGE



Ortam koşulları
İşleyiş:
-10 °C ila +40 °C (+14 °F ila +104 °F)

Taşıma ve depolama:
-25 °C ila +55 °C (-13 °F ila +131 °F)

Bağıl nem:
20 °C'de (68 °F) %90'a kadar

Kullanımdan sonra bu ürünü gereken bir şekilde bertaraf edin. Torçlar ve kullanılmış parçalar, yerel gereksinimlere/ yönetmeliklere göre uygun şekilde geri dönüştürülmelidir.



GÜVENLİK ÖNLEMLERİ



Yerel yönetmeliklere uygun olarak eldiven ve diğer uygun iş kıyafetlerini giyin.



Ark gözler için tehlikelidir. Koruyucu bir maske takın. Yakındaki insanlar göz koruyucu ekipman takmalıdır.



Yanıcı veya patlayıcı alanlarda kaynak yapmayın.



Dumanlar sağlığa zararlıdır. Duman tahliye sistemlerini kullanın veya yalnızca havalandırılan alanlarda kaynak yapın.



Torcu kendinizden ve başkalarından uzağa doğrultun.



Boyalı yüzeylerde kaynak yapmayın.



Elektrikli aletleri yağmurdan koruyun. Torcu ıslak yüzeylerde/zeminlerde veya yüksek nemli ortamlarda kullanmayın.



Torç kabloları ağır nesnelere ezilmemelidir.



Torç üzerinde değişiklik veya yapısal değişiklikler yapmayın.

BAĞLANTI



Torcu bağlamadan önce, güç kaynağını kapatın, elektrik fişini çekin ve gaz kaynağını kapatın.



Torcu güç kaynağına bağlamadan önce, varsa ekteki kablo şemalarına göre doğru elektrik bağlantılarını kontrol edin.



Torç soğutma sıvısı sirkülasyonunu/ akışını kontrol edin.

NO VOLTAGE



KULLANIM



Spiral ve kontak memenin dolgu telinin çapıyla eşleştiğinden emin olun.



Düzgün gaz ve soğutma sıvısı sirkülasyonunu engelleyebilecek hasarları önlemek için kabloları ve hortumları bükmeyin.



Torcu kaynak yapmak dışında başka amaçlar için kullanmayın.

BAKIM



Torç bakımını gerçekleştirmeden önce güç kaynağını kapatın. Herhangi bir yedek parça değişimi veya diğer bakım işlemleri torç soğuduktan sonra gerçekleştirilmelidir.



Aşınmış veya hasarlıysa kontak memeyi değiştirin.



Gaz nozulunu ve gaz difüzörünü düzenli aralıklarla temizleyin. Çapak önleyici sprey kullanın.

NO VOLTAGE



Tel besleme ile ilgili sorunlar varsa spirali değiştirin.



Kablonun durumunu kontrol edin ve periyodik olarak devam edin. Onarımlar yalnızca nitelikli personel tarafından gerçekleştirilebilir.



Daima orijinal Trafimet yedek parçalarını ve sarf malzemelerini kullanın.

İŞLEYİŞ:



MIG kaynak torcunun güvenli şekilde çalıştırılmasına ilişkin önemli bilgiler. Torç üzerinde bulunan elektrik kontrollerinin derecesi: 32 VDC 0,05 A.

Su soğutmalı torçlar için soğutma ünitesi gücü: Minimum 800 W.



Torcu kullanmadan önce tüm kabloların çalışır durumda olduğundan ve soketlerin doğru şekilde bağlandığından emin olun.

Torç nasıl bağlanır?

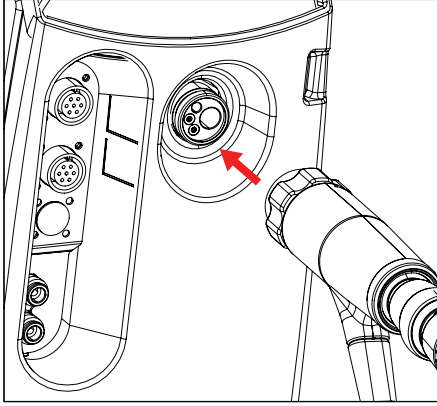

Torcu kaynak makinenize bağlayın. Sıkma bileziğini saat yönünde çevirerek soketi yerine sabitleyin.

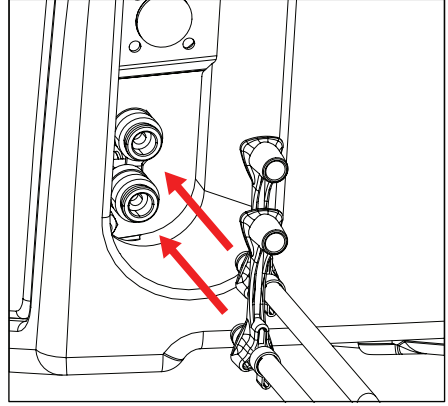

Soğutma sıvısı giriş ve çıkış hortumunu kaynak ekipmanınıza bağlayın. Soketlerin renk kodlu olduğunu unutmayın.



Soğutma sıvısı hortumlarını doğru hortum bağlantılarına bağladığınızdan emin olun. Bağlantılar yanlış takılırsa kaynak torcunda aşırı ısınma meydana gelebilir.

İŞLEYİŞ:

Spiral nasıl takılır ve değiştirilir?

ERGOPLUS MIG kaynak torçları, önceden monte edilmiş spiral ile teslim edilir. Spiralın değiştirilmesi gerekirse bu bölüme bakın. Spiral, aşındığında ve dolgu teli malzemesi değiştiğinde değiştirilmesi gereken bir sarf malzemesidir.



Dolgu telini farklı bir çap veya malzeme ile değiştirirseniz, tel sürme sistemindeki sürücü makaraları da buna göre değiştirin. Spiral değiştirilmeden önce dolgu teli çıkarılmalıdır.

- 1 Torcu düz bir yüzey üzerine yatırın ve spiral somununu sökün.

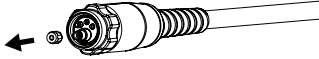

- 2 Gaz nozulunu ve kontak memeyi çıkarın. Spiral, kontak meme tutucunun içinden geçmezse kontak meme tutucuyu da çıkarın.

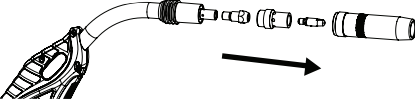

- 3 Spirali 1-2 mm fazla spiral bırakarak kesin.

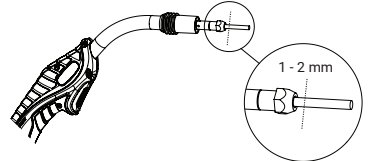
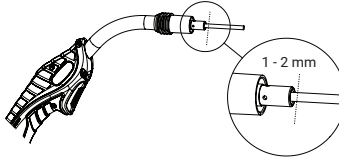

- 4 Dolgu teline zarar verme olasılığı bulunan pürüzlü kenarları düzeltin.

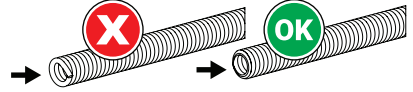

- 5

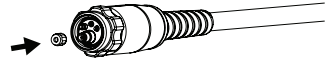

Pistol kabza nasıl takılır ve çıkarılır

- 1 Pistol kabzanın iç çentiklerini, pistol kabzanın alt tarafı ileriye bakacak şekilde torç üzerindeki yivlerin üzerine oturtun.

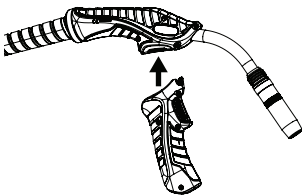

- 2 Kilitlemek için pistol kabzayı geriye doğru çekin.

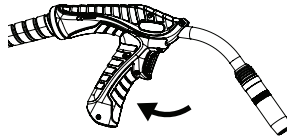

- 3 Pistol kabzayı çıkarmak için, pistol kabzanın arka kısmındaki kilitleme düğmesine basın.

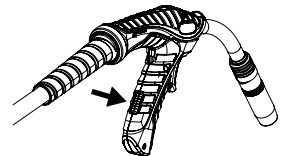



MIG WELDING (GMAW) TORCHES

ERGOPLUS 240

CE EN60974-7



CODE	↔			
	3 m	10'		
MB2600-030	3 m	10'		1
MB2600-040	4 m	12'		1
MB2600-050	5 m	16.4'	EURO	1

TECHNICAL DATA		
	ERGOPLUS 240	
	1,1 kg	2.43 lb
	113	
	0,8 + 1,2 mm	.030" + .045"
	300A CO2 - 270A Mix	
	2-4 bar	
	1,6 l/min	

MIG Standard equipment in all torch packages



MT0566

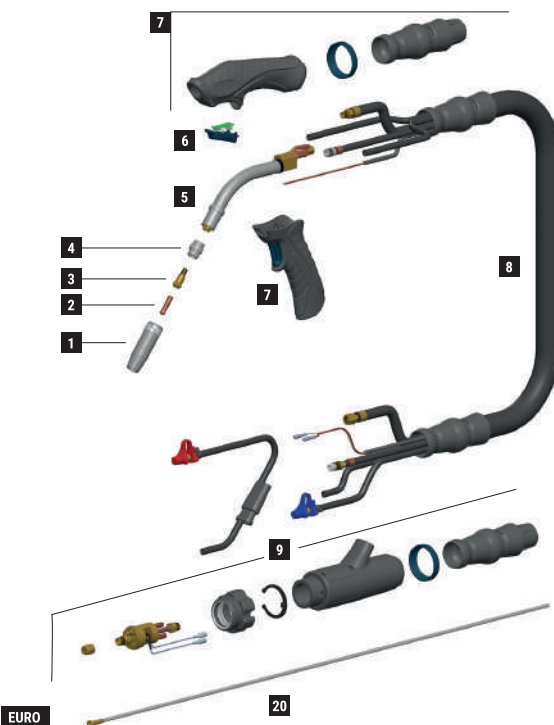

	CODE			Ø		←→	REF		
1	MC0301		nozzle	12,5 mm	1/2"	63,5 mm	2-1/2"	145.0080	10
2	MD0008-08		M6 - Cu	0,8 mm	.030"	25 mm	31/32"	140.0059	20
3	MD0138-00		M6 - brass			26 mm	1" 1/32"	142.0003	20
4	ME0584		ceramic			20 mm	25/32"	-	10
20	GM0526		uncoated steel liner	1,0 ÷ 1,2 mm	.040" ÷ .045"	3 m	10'		1
20	GM0527		uncoated steel liner	1,0 ÷ 1,2 mm	.040" ÷ .045"	4 m	12'		1
20	GM0528		uncoated steel liner	1,0 ÷ 1,2 mm	.040" ÷ .045"	5 m	16.4'		1

***Complete list of available consumables at the end of this section**

	CODE			
5	MG0284		Ergoplus 240 torch head	1
6	MT0563		trigger kit	1
7	MT0560		handle kit	1
7	MT0566		pistol grip	1
8	MN2014-030		cable assembly - 3 m / 10' with ball-joints	1
8	MN2014-040		cable assembly - 4 m / 12' with ball-joints	1

	CODE			
8	MN2014-050		cable assembly - 5 m / 16.4' with ball-joints	1
9	AR0052		EURO connector - air	1
9	BW0020		metal EURO nut	10
9	FA0026		liner nut M10x1	10
9	MT0564		back box kit	1

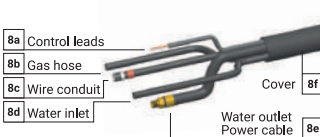

	CODE	←→
8a	BX1421-030	3 m / 10'
8b	QB0231-030	3 m / 10'
8c	QB0230-030	3 m / 10'
8d	QB0232-030	3 m / 10'
8e	QA0030-030	3 m / 10'
8f	MQ0125-030	3 m / 10'

	CODE	←→
8a	BX1421-040	4 m / 12'
8b	QB0231-040	4 m / 12'
8c	QB0230-040	4 m / 12'
8d	QB0232-040	4 m / 12'
8e	QA0030-040	4 m / 12'
8f	MQ0125-040	4 m / 12'

	CODE	←→
8a	BX1421-050	5 m / 16.4'
8b	QB0231-050	5 m / 16.4'
8c	QB0230-050	5 m / 16.4'
8d	QB0232-050	5 m / 16.4'
8e	QA0030-050	5 m / 16.4'
8f	MQ0125-050	5 m / 16.4'

STANDARD













MIG WELDING (GMAW) TORCHES

ERGOPLUS 400

CE EN60974-7



CODE	↔			
MB2601-030	3 m	10'		1
MB2601-040	4 m	12'		1
MB2601-050	5 m	16.4'	EURO	1

TECHNICAL DATA	
	ERGOPLUS 400
	1,25 kg 2.76 lb
	113
	1,0 ÷ 1,6 mm .040" ÷ .1/16"
	400A CO2 - 350A Mix
	2÷4 bar
	1,6 l/min

MIG *Standard equipment
in all torch packages*



MT0566

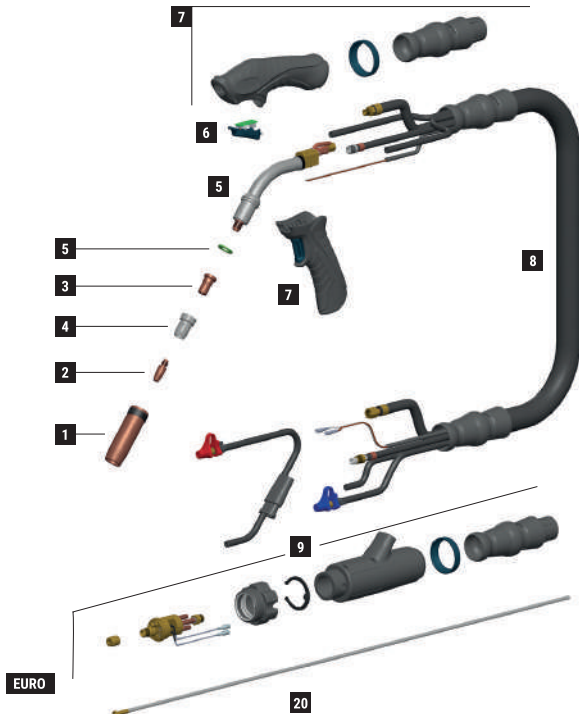

	CODE			Ø	↔	REF			
1	MC0568		quick release nozzle - 2,5 mm thickness	16 mm	5/8"	76 mm	3"	-	10
2	MD0005-82		M8 - CuCrZr	1,2 mm	.045"	30 mm	1"-3/16	140.0445	20
3	ME0390		M8 - copper			25 mm	31/32"	-	10
4	ME0579		ceramic	16 mm	5/8"	28 mm	1"-3/32	-	10
20	GM0530		uncoated steel liner	1,2 ÷ 1,6 mm	.045" ÷ 1/16"	3 m	10'		1
20	GM0531		uncoated steel liner	1,2 ÷ 1,6 mm	.045" ÷ 1/16"	4 m	12'		1
20	GM0532		uncoated steel liner	1,2 ÷ 1,6 mm	.045" ÷ 1/16"	5 m	16.4'		1

***Complete list of available consumables at the end of this section**

	CODE			
5	FB1278		Insulator	10
5	MG0285		Ergoplus 400 torch head	1
6	MT0563		trigger kit	1
7	MT0560		handle kit	1
7	MT0566		pistol grip	1
8	MN2014-030		cable assembly - 3 m / 10' with ball-joints	1

	CODE			
8	MN2014-040		cable assembly - 4 m / 12' with ball-joints	1
8	MN2014-050		cable assembly - 5 m / 16.4' with ball-joints	1
9	AR0052		EURO connector	1
9	BW0020		metal EURO nut	10
9	FA0026		liner nut M10x1	10
9	MT0564		back box kit	1

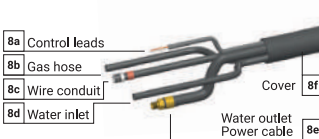

	CODE	↔
8a	BX1421-030	3 m / 10'
8b	QB0231-030	3 m / 10'
8c	QB0230-030	3 m / 10'
8d	QB0232-030	3 m / 10'
8e	QA0030-030	3 m / 10'
8f	MQ0125-030	3 m / 10'

	CODE	↔
8a	BX1421-040	4 m / 12'
8b	QB0231-040	4 m / 12'
8c	QB0230-040	4 m / 12'
8d	QB0232-040	4 m / 12'
8e	QA0030-040	4 m / 12'
8f	MQ0125-040	4 m / 12'

	CODE	↔
8a	BX1421-050	5 m / 16.4'
8b	QB0231-050	5 m / 16.4'
8c	QB0230-050	5 m / 16.4'
8d	QB0232-050	5 m / 16.4'
8e	QA0030-050	5 m / 16.4'
8f	MQ0125-050	5 m / 16.4'



MIG WELDING (GMAW) TORCHES

ERGOPLUS 400R

CE EN60974-7



CODE					
MB2631-030	50°	3 m	10'		1
MB2631-040	50°	4 m	12'		1
MB2631-050	50°	5 m	16.4'		1
MB2631-030-3000	30°	3 m	10'		1
MB2631-040-3000	30°	4 m	12'		1
MB2631-050-3000	30°	5 m	16.4'		1



EURO

TECHNICAL DATA		
	ERGOPLUS 400R	
	1,39kg	3.06 lb
	V PEAK 113	
	1,0 ÷ 1,6 mm	.040" ÷ zzzzzz1/16"
	X 100% 400A CO2 - 350A Mix	
	2÷4 bar	
	1,6 l/min	

MIG *Standard equipment in all torch packages*

MT0566

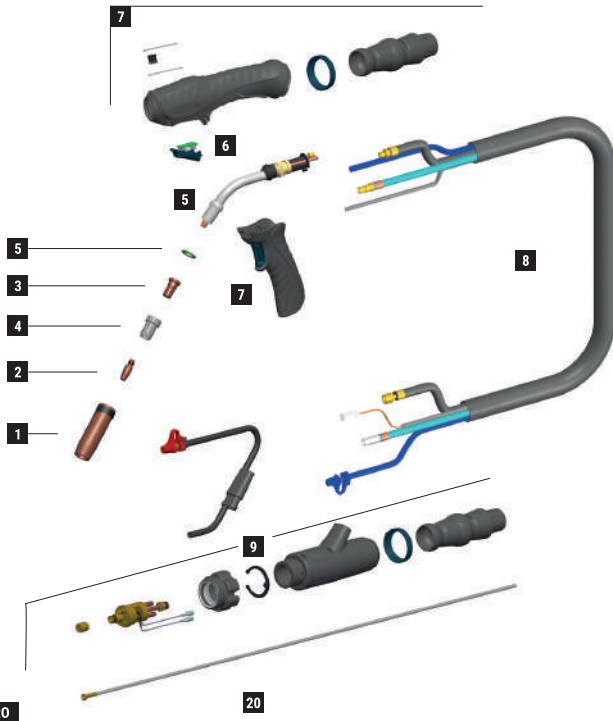

EURO

20

	CODE			Ø	↔	REF			
1	MC0568		quick release nozzle - 2,5 mm thickness	16 mm	5/8"	76 mm	3"	-	10
2	MD0005-82		M8 - CuCrZr	1,2 mm	.045"	30 mm	1"-3/16	140.0445	20
3	ME0390		M8 - copper			25 mm	31/32"	-	10
4	ME0579		ceramic	16 mm	5/8"	28 mm	1"-3/32	-	10
20	GM0530		uncoated steel liner	1,2 ÷ 1,6 mm	.045" ÷ 1/16"	3 m	10'		1
20	GM0531		uncoated steel liner	1,2 ÷ 1,6 mm	.045" ÷ 1/16"	4 m	12'		1
20	GM0532		uncoated steel liner	1,2 ÷ 1,6 mm	.045" ÷ 1/16"	5 m	16.4'		1

***Complete list of available consumables at the end of this section**

	CODE			
5	FB1278		Insulator	10
5	MG0298-SP		Ergoplus 400R torch head 50°	1
5	MG0299-SP		Ergoplus 400R torch head 30°	1
6	MT0594		trigger kit	1
7	MT0593		handle kit	1
7	MT0566		pistol grip	1
8	MN2018-030-SP		cable assembly - 3 m / 10' with ball-joints	1

	CODE			
8	MN2018-040-SP		cable assembly - 4 m / 12' with ball-joints	1
8	MN2018-050-SP		cable assembly - 5 m / 16.4' with ball-joints	1
9	AR0110-SP		EURO connector	1
9	BW0020		metal EURO nut	10
9	FA0026		liner nut M10x1	10
9	MT0564		back box kit	1

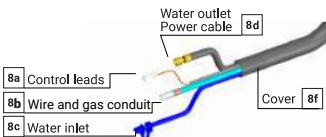

	CODE	↔
8a	BX1422-030-SP	3 m / 10'
8b	MH1262-030-SP	3 m / 10'
8c	QB0076	3 m / 10'
8d	QA0019	3 m / 10'
8f	MQ0125-030	3 m / 10'

	CODE	↔
8a	BX1422-040-SP	4 m / 12'
8b	MH1262-040-SP	4 m / 12'
8c	QB0077	4 m / 12'
8d	QA0020	4 m / 12'
8f	MQ0125-040	4 m / 12'

	CODE	↔
8a	BX1422-050-SP	5 m / 16.4'
8b	MH1262-050-SP	5 m / 16.4'
8c	QB0078	5 m / 16.4'
8d	QA0021	5 m / 16.4'
8f	MQ0125-050	5 m / 16.4'

STANDARD



MIG WELDING (GMAW) TORCHES

ERGOPLUS 500

CE EN60974-7



CODE					
MB2602-030	50°	3 m	10'	 EURO	1
MB2602-040	50°	4 m	12'		1
MB2602-050	50°	5 m	16.4'		1
MB2602-060	50°	6 m	19.6'		1
MB2602-080	50°	8 m	26.2'		1
MB2602-030-3000	30°	3 m	10'		1
MB2602-040-3000	30°	4 m	12'		1
MB2602-050-3000	30°	5 m	16.4'		1

TECHNICAL DATA		
	ERGOPLUS 500	
	1,25 kg	2.76 lb
	113	
	1,0 ÷ 2,4 mm	.040" ÷ 3/32"
	500A CO2 - 450A Mix	
	2÷4 bar	
	1,6 l/min	

MIG *Standard equipment in all torch packages*

MT0566

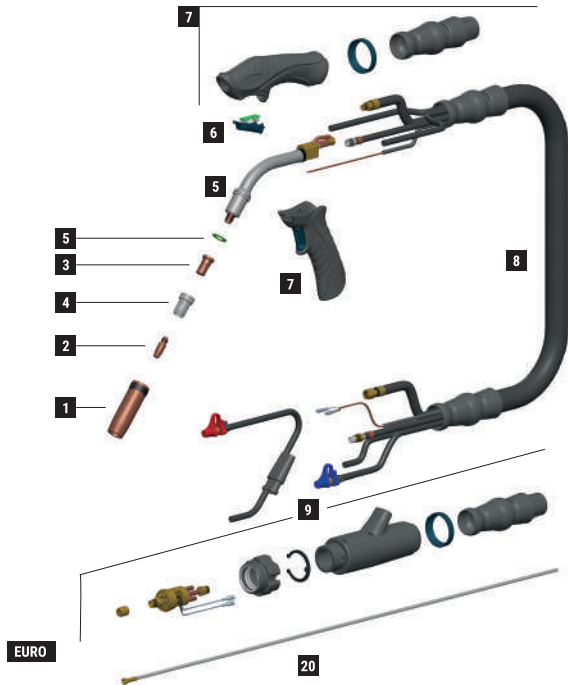

	CODE			Ø	↔	REF			
1	MC0568		quick release nozzle - 2,5 mm thickness	16 mm	5/8"	76 mm	3"	-	10
2	MD0005-82		M8 - CuCrZr	1,2 mm	.045"	30 mm	1"-3/16	140.0445	20
3	ME0390		M8 - copper			25 mm	31/32"	-	10
4	ME0579		ceramic	16 mm	5/8"	28 mm	1"-3/32	-	10
20	GM0530		uncoated steel liner	1,2 ÷ 1,6 mm	.045" ÷ 1/16"	3 m	10'		1
20	GM0531		uncoated steel liner	1,2 ÷ 1,6 mm	.045" ÷ 1/16"	4 m	12'		1
20	GM0532		uncoated steel liner	1,2 ÷ 1,6 mm	.045" ÷ 1/16"	5 m	16.4'		1
20	GM0533		uncoated steel liner	1,2 ÷ 1,6 mm	.045" ÷ 1/16"	6 m	19.6'		1
20	GM0785		yellow teflon liner with copper terminal	1,2 ÷ 1,6 mm	.045" ÷ 1/16"	8 m	26.2'		1

***Complete list of available consumables at the end of this section**

	CODE			
5	FB1278		Insulator	10
5	MG0286		Ergoplus 500 torch head	1
5	MG0295-SP		Ergoplus 500 torch head 30"	1
6	MT0563		trigger kit	1
7	MT0560		handle kit	1
7	MT0566		pistol grip	1
8	MN2014-030		cable assembly - 3 m / 10' with ball-joints	1
8	MN2014-040		cable assembly - 4 m / 12'	1

	CODE			
8	MN2014-050		cable assembly - 5 m / 16.4'	1
8	MN2014-060		cable assembly - 6 m / 19.6'	1
8	MN2014-080		cable assembly - 8 m / 26.2'	1
9	AR0052		EURO connector	1
9	BW0020		metal EURO nut	10
9	FA0026		liner nut M10x1	10
9	MT0564		back box kit	1

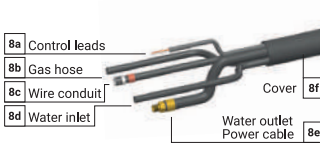

	CODE	↔
8a	BX1421-030	3 m / 10'
8b	QB0231-030	3 m / 10'
8c	QB0230-030	3 m / 10'
8d	QB0232-030	3 m / 10'
8e	QA0030-030	3 m / 10'
8f	MQ0125-030	3 m / 10'

	CODE	↔
8a	BX1421-040	4 m / 12'
8b	QB0231-040	4 m / 12'
8c	QB0230-040	4 m / 12'
8d	QB0232-040	4 m / 12'
8e	QA0030-040	4 m / 12'
8f	MQ0125-040	4 m / 12'

	CODE	↔
8a	BX1421-050	5 m / 16.4'
8b	QB0231-050	5 m / 16.4'
8c	QB0230-050	5 m / 16.4'
8d	QB0232-050	5 m / 16.4'
8e	QA0030-050	5 m / 16.4'
8f	MQ0125-050	5 m / 16.4'

	CODE	↔
8a	BX1421-060	6 m / 19.6'
8b	QB0231-060	6 m / 19.6'
8c	QB0230-060	6 m / 19.6'
8d	QB0232-060	6 m / 19.6'
8e	QA0030-060	6 m / 19.6'
8f	MQ0125-060	6 m / 19.6'

	CODE	↔
8a	BX1421-080	8 m / 26.2'
8b	QB0231-080	8 m / 26.2'
8c	QB0230-080	8 m / 26.2'
8d	QB0232-080	8 m / 26.2'
8e	QA0030-080	8 m / 26.2'
8f	MQ0125-080	8 m / 26.2'



MIG WELDING (GMAW) TORCHES

ERGOPLUS 500 SPECIAL

CE EN60974-7



CODE					
MB2602-030-5010	MG0282-10-SP	3 m	10'		1
MB2602-040-5010	MG0282-10-SP	4 m	12'		1
MB2602-050-5010	MG0282-10-SP	5 m	16.4'		1
MB2602-030-5016	MG0282-16-SP	3 m	10'		1
MB2602-040-5016	MG0282-16-SP	4 m	12'		1
MB2602-050-5016	MG0282-16-SP	5 m	16.4'		1
MB2602-030-5030	MG0282-30-SP	3 m	10'		1
MB2602-040-5030	MG0282-30-SP	4 m	12'		1
MB2602-050-5030	MG0282-30-SP	5 m	16.4'		1
MB2602-030-5050	MG0282-50-SP	3 m	10'		1
MB2602-040-5050	MG0282-50-SP	4 m	12'		1
MB2602-050-5050	MG0282-50-SP	5 m	16.4'		1
MB2602-030-5070	MG0282-70-SP	3 m	10'		1
MB2602-040-5070	MG0282-70-SP	4 m	12'		1
MB2602-050-5070	MG0282-70-SP	5 m	16.4'	1	

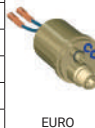

EURO

TECHNICAL DATA		
ERGOPLUS 500		
	1,25 kg	2.76 lb
	113	
	1,0 ÷ 2,4 mm	.040" ÷ 3/32"
	500A CO2 - 450A Mix	
	2÷4 bar	
	1,6 l/min	

MIG *Standard equipment in all torch packages*

MT0566

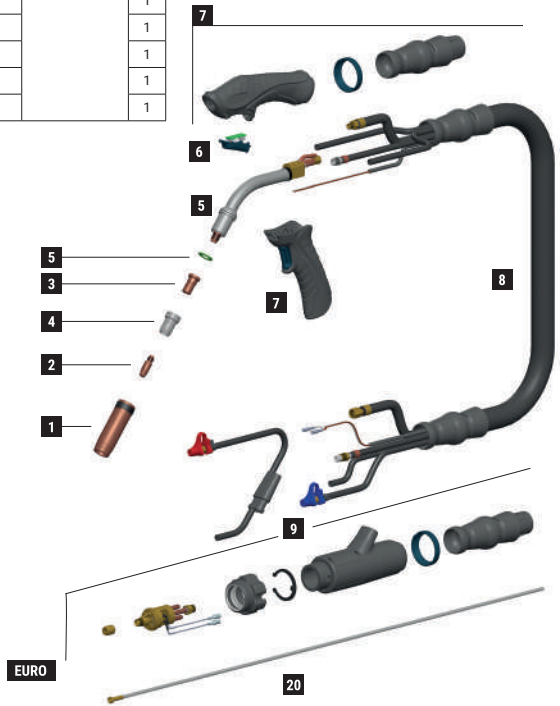

EURO

	CODE			Ø		←→	REF		
1	MC0568		quick release nozzle - 2,5 mm thickness	16 mm	5/8"	76 mm	3"	-	10
2	MD0005-82		M8 - CuCrZr	1,2 mm	.045"	30 mm	1"-3/16	140.0445	20
3	ME0390		M8 - copper			25 mm	31/32"	-	10
4	ME0579		ceramic	16 mm	5/8"	28 mm	1"-3/32	-	10
20	GM0530		uncoated steel liner	1,2 ÷ 1,6 mm	.045" ÷ 1/16"	3 m	10'		1
20	GM0531		uncoated steel liner	1,2 ÷ 1,6 mm	.045" ÷ 1/16"	4 m	12'		1
20	GM0532		uncoated steel liner	1,2 ÷ 1,6 mm	.045" ÷ 1/16"	5 m	16.4'		1

***Complete list of available consumables at the end of this section**

	CODE			
5	FB1278		Insulator	10
5	MG0282-10-SP		Ergoplus 500 torch head 100 mm	1
5	MG0282-16-SP		Ergoplus 500 torch head 160 mm	1
6	MG0282-30-SP		Ergoplus 500 torch head 300 mm	1
5	MG0282-50-SP		Ergoplus 500 torch head 500 mm	1
5	MG0282-70-SP		Ergoplus 500 torch head 700 mm	1
7	MT0563		trigger kit	1
7	MT0560		handle kit	1
7	MT0566		pistol grip	1
8	MN2014-030		cable assembly - 3 m / 10' with ball-joints	1
8	MN2014-040		cable assembly - 4 m / 12'	1

	CODE			
8	MN2014-050		cable assembly - 5 m / 16.4'	1
9	AR0052		EURO connector	1
9	BW0020		metal EURO nut	10
9	FA0026		liner nut M10x1	10
9	MT0564		back box kit	1

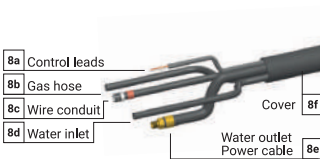

	CODE	←→
8a	BX1421-030	3 m / 10'
8b	QB0231-030	3 m / 10'
8c	QB0230-030	3 m / 10'
8d	QB0232-030	3 m / 10'
8e	QA0030-030	3 m / 10'
8f	MQ0125-030	3 m / 10'

	CODE	←→
8a	BX1421-040	4 m / 12'
8b	QB0231-040	4 m / 12'
8c	QB0230-040	4 m / 12'
8d	QB0232-040	4 m / 12'
8e	QA0030-040	4 m / 12'
8f	MQ0125-040	4 m / 12'

	CODE	←→
8a	BX1421-050	5 m / 16.4'
8b	QB0231-050	5 m / 16.4'
8c	QB0230-050	5 m / 16.4'
8d	QB0232-050	5 m / 16.4'
8e	QA0030-050	5 m / 16.4'
8f	MQ0125-050	5 m / 16.4'

STANDARD



MIG WELDING (GMAW) TORCHES

ERGOPLUS 500R

CE EN60974-7



CODE				
MB2632-030	50°	3 m	10'	1
MB2632-040	50°	4 m	12'	1
MB2632-050	50°	5 m	16.4'	1
MB2632-030-3000	30°	3 m	10'	1
MB2632-040-3000	30°	4 m	12'	1
MB2632-050-3000	30°	5 m	16.4'	1
MB2632-030-5005	L 50°	3 m	10'	1
MB2632-040-5005	L 50°	4 m	12'	1
MB2632-050-5005	L 50°	5 m	16.4'	1
MB2632-030-3005	L 30°	3 m	10'	1
MB2632-040-3005	L 30°	4 m	12'	1
MB2632-050-3005	L 30°	5 m	16.4'	1
MB2632-030-5016	XL 50°	3 m	10'	1
MB2632-040-5016	XL 50°	4 m	12'	1
MB2632-050-5016	XL 50°	5 m	16.4'	1
MB2632-030-3016	XL 30°	3 m	10'	1
MB2632-040-3016	XL 30°	4 m	12'	1
MB2632-050-3016	XL 30°	5 m	16.4'	1



EURO

TECHNICAL DATA		
	ERGOPLUS 500R	
	1,39 kg	3.06 lb
	113	
	1,0 + 2,4 mm	.040" ± 3/32"
	500A CO2 - 450A Mix	
	2+4 bar	
	1,6 l/min	

MIG *Standard equipment in all torch packages*



MT0566

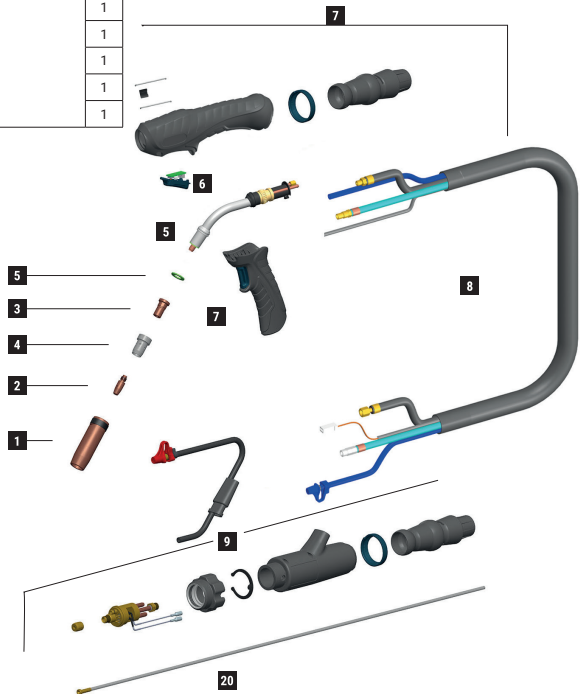

	CODE			Ø		↔	REF		
1	MC0568		quick release nozzle - 2,5 mm thickness	16 mm	5/8"	76 mm	3"	-	10
2	MD0005-82		M8 - CuCrZr	1,2 mm	.045"	30 mm	1"-3/16	140.0445	20
3	ME0390		M8 - copper			25 mm	31/32"	-	10
4	ME0579		ceramic	16 mm	5/8"	28 mm	1"-3/32	-	10
20	GM0530		uncoated steel liner	1,2 ÷ 1,6 mm	.045" ÷ 1/16"	3 m	10'		1
20	GM0531		uncoated steel liner	1,2 ÷ 1,6 mm	.045" ÷ 1/16"	4 m	12'		1
20	GM0532		uncoated steel liner	1,2 ÷ 1,6 mm	.045" ÷ 1/16"	5 m	16.4'		1

***Complete list of available consumables at the end of this section**

	CODE			
5	FB1278		Insulator	10
5	MG0301-SP		Ergoplus 500R torch head 50°	1
5	MG0302-SP		Ergoplus 500R torch head 30°	1
5	MG0303-SP		Ergoplus 500R torch head 50° L	1
5	MG0304-SP		Ergoplus 500R torch head 30° L	1
5	MG0305-SP		Ergoplus 500R torch head 50° XL	1
5	MG0306-SP		Ergoplus 500R torch head 30° XL	1
6	MT0594		trigger kit	1

	CODE			
7	MT0593		handle kit	1
7	MT0566		pistol grip	1
8	MN2018-030-SP		cable assembly - 3 m / 10'	1
8	MN2018-040-SP		cable assembly - 4 m / 12'	1
8	MN2018-050-SP		cable assembly - 5 m / 16.4'	1
9	AR0110-SP		EURO connector	1
9	BW0020		metal EURO nut	10
9	FA0026		liner nut M10x1	10
9	MT0564		back box kit	1

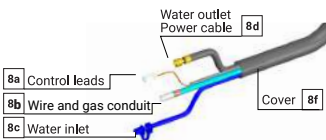

	CODE	↔
8a	BX1422-030-SP	3 m / 10'
8b	MH1262-030-SP	3 m / 10'
8c	QB0076	3 m / 10'
8d	QA0019	3 m / 10'
8f	MQ0125-030	3 m / 10'

	CODE	↔
8a	BX1422-040-SP	4 m / 12'
8b	MH1262-040-SP	4 m / 12'
8c	QB0077	4 m / 12'
8d	QA0020	4 m / 12'
8f	MQ0125-040	4 m / 12'

	CODE	↔
8a	BX1422-050-SP	5 m / 16.4'
8b	MH1262-050-SP	5 m / 16.4'
8c	QB0078	5 m / 16.4'
8d	QA0021	5 m / 16.4'
8f	MQ0125-050	5 m / 16.4'

STANDARD



MIG WELDING (GMAW) TORCHES

ERGOPLUS 555

CE EN60974-7



CODE	↔			
MB2603-030	3 m	10'		1
MB2603-040	4 m	12'		1
MB2603-050	5 m	16.4'	EURO	1

TECHNICAL DATA		
	ERGOPLUS 555	
	1,30 kg	2.87 lb
	V PEAK 113	
	1,0 ÷ 2,4 mm	.040" ÷ 3/32"
	X 100% 550A CO2 - 500A Mix	
	2÷4 bar	
	1,6 l/min	

MIG

Standard equipment
in all torch packages



MT0566

ERGOPLUS 555

REPAIR KIT FOR TORCH HEAD MT0211

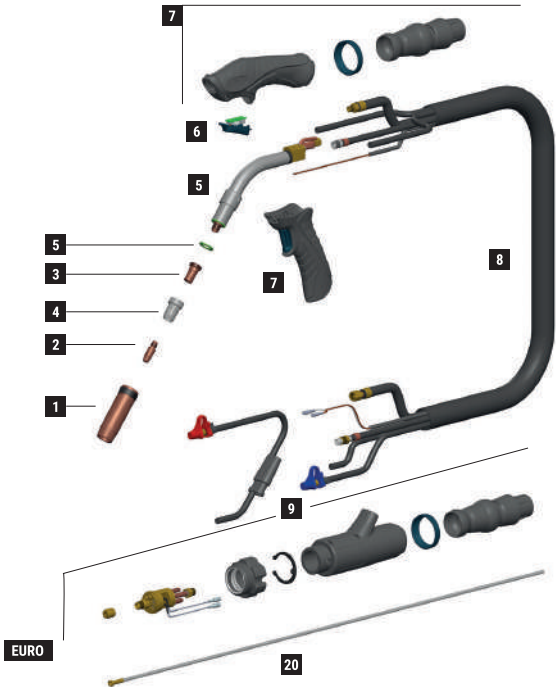

	CODE			Ø		←→	REF		
1	MC0568		quick release nozzle - 2,5 mm thickness	16 mm	5/8"	76 mm	3"	-	10
2	MD0005-82		M8 - CuCrZr	1,2 mm	.045"	30 mm	1"-3/16	140.0445	20
3	ME0402		M8 - copper			25 mm	31/32"	-	10
4	ME0579		ceramic	16 mm	5/8"	28 mm	1"-3/32	-	10
20	GM0530		uncoated steel liner	1,2 ÷ 1,6 mm	.045" ÷ 1/16"	3 m	10'		1
20	GM0531		uncoated steel liner	1,2 ÷ 1,6 mm	.045" ÷ 1/16"	4 m	12'		1
20	GM0532		uncoated steel liner	1,2 ÷ 1,6 mm	.045" ÷ 1/16"	5 m	16.4'		1

***Complete list of available consumables at the end of this section**

	CODE			
5	FB1278		insulator	10
5	MG0287		Ergoplus 555 torch head	1
6	MT0563		trigger kit	1
7	MT0561		handle kit	1
7	MT0566		pistol grip	1
8	MN2014-030		cable assembly - 3 m / 10' with ball-joints	1

	CODE			
8	MN2014-040		cable assembly - 4 m / 12' with ball-joints	1
8	MN2014-050		cable assembly - 5 m / 16.4' with ball-joints	1
9	AR0052		EURO connector	1
9	BW0020		metal EURO nut	10
9	FA0026		liner nut M10x1	10
9	MT0564		back box kit	1

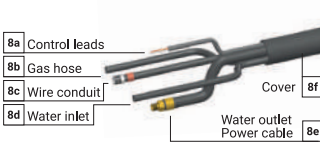

	CODE	←→
8a	BX1421-030	3 m / 10'
8b	QB0231-030	3 m / 10'
8c	QB0230-030	3 m / 10'
8d	QB0232-030	3 m / 10'
8e	QA0030-030	3 m / 10'
8f	MQ0125-030	3 m / 10'

	CODE	←→
8a	BX1421-040	4 m / 12'
8b	QB0231-040	4 m / 12'
8c	QB0230-040	4 m / 12'
8d	QB0232-040	4 m / 12'
8e	QA0030-040	4 m / 12'
8f	MQ0125-040	4 m / 12'

	CODE	←→
8a	BX1421-050	5 m / 16.4'
8b	QB0231-050	5 m / 16.4'
8c	QB0230-050	5 m / 16.4'
8d	QB0232-050	5 m / 16.4'
8e	QA0030-050	5 m / 16.4'
8f	MQ0125-050	5 m / 16.4'









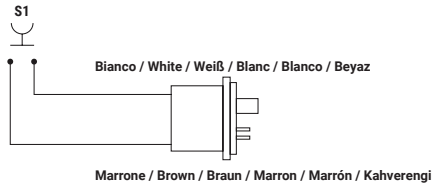











STANDARD















CONNECTIONS

Euro connector



	Description
	Length
	Thickness
	Diameter
Gr	Weight of TIG ceramic nozzles
	Connection type
	Plasma cutting torch type
	MIG (GMAW) welding torch type
	TIG (GTAW) welding torch type
	Tungsten electrode type
REF	International reference
	Quantity per pack
PCS X 	Pieces per blister
X 	Blisters per box
PCS X 	Pieces per box/kit
	Air cooling
	Water cooling
	Plasma torch weight at a height of 1 meter
	MIG torch weight at a height of 1 meter
	TIG torch weight at a height of 1 meter
NO HF	Plasma torch without high frequency
HF	Plasma torch with high frequency
V PEAK	Voltage class
	Air pressure
	Air consumption
	Cutting thickness

	Cooling liquid pressure
V MOTOR	Motor voltage
	Gas type
X 35%	Duty cycle @ 35%
X 60%	Duty cycle @ 60%
X 100%	Duty cycle @ 100%
A	Ampere
	Wire diameter
Ø SPEED	Wire feed speed
	Electrode diameter
	Contact cutting short wear parts
	Contact cutting long wear parts
	Drag cutting short wear parts
	Drag cutting long wear parts
	Gouging wear parts
TIP HOLE	Tip hole to be used with the flow meter during the air flow test
Ø RING	O-ring (used for liners)
	Fixed head (used for liners)
	Passing head (used for liners)
Ø INT	Internal diameter
Ø EXT	External diameter
Ø NO COVER	External diameter without cover (used for liners)
	Hexagon size
AWG	American Wire Gauge
	Cable size (diameter)



Trafimet Group SpA
info@trafimet.com
www.trafimet.com

TRAFIMET WORLDWIDE

Trafimet Group Spa

Via del Lavoro, 8
36020 Castegnero
Vicenza, Italy
Ph. +39 0444739900
Fax +39 0444739999
info@trafimet.com

Trafimet Schweisstechnik GmbH

Bismarckstraße 9
36251 Bad Hersfeld
Deutschland
Ph. +49 6621 510960
info@trafimet.de

Trafimet Kaynak Sistemleri A.Ş.

İkitelli O.S.B. Heskop H Blok
Sinpaş İş Modern Ticaret Merkezi
Kat.3 No.66 Başakşehir 34490
İstanbul, Türkiye
Ph. +90 212 8091700
Fax +90 212 8091703
info@trafimet.com.tr